

# University of Minnesota Nano Fabrication Center

## Standard Operating Procedure

**Equipment Name:** YES 310 Image Reversal Processing System  
**Coral Name:**  
**Model:**  
**Location:** Bay 2

**Revision Number:** 2  
**Revisionist:** P. Kimani  
**Date:** 08/22/2008

YES-310

ANHYDROUS AMMONIA GAS  
IMAGE REVERSAL SYSTEM

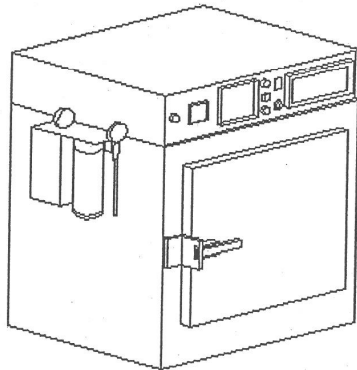

### 1. Description

The Yield Engineering Systems' YES-310 is a dual function system that uses anhydrous ammonia gas for image reversal. It also can function as a vacuum bake/vapor priming system, although this option is not available at NFC.

Image reversal allows the control of the slope of the photoresist wall to regulate Critical Dimension (CD) problems and enhance resolution of the image. By reversing the slope of the walls of the photoresist, the walls remain exposed after metal deposition, so that a simple resist strip can "lift off" unwanted metal from the substrate without causing notching or "mouse bites".

The exposed photoresist is placed in anhydrous ammonia gas at 90 °C. The ammonia acts as a base catalyst. The carboxylic acid from the exposed resist releases CO<sub>2</sub> and ceases to be acidic. After a blanket exposure to U.V. light, the areas originally unexposed are activated. The blanket exposure has to be at least 1½ times normal exposure because some of the resist sensitizer may have been neutralized after the bake.

The flood exposure can only affect the originally unexposed resist, causing it to be easily removed in the normal positive resist developer.

# University of Minnesota Nano Fabrication Center

## Standard Operating Procedure

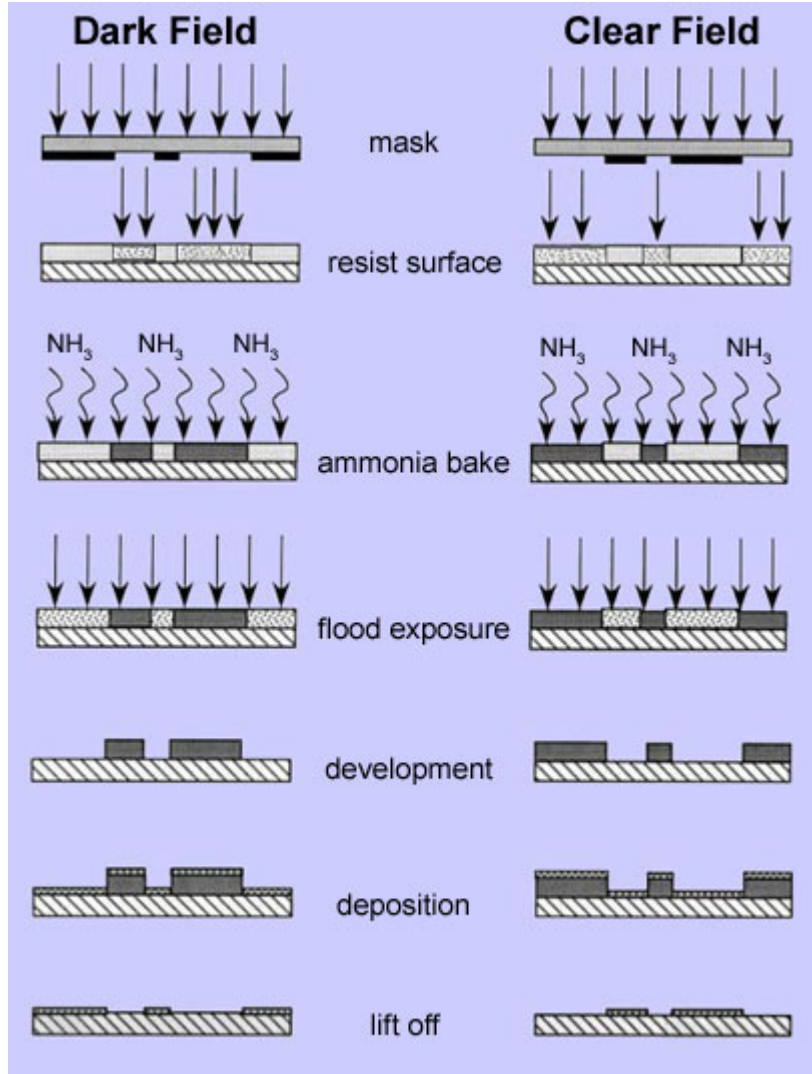

**Figure 1:** Image Reversal Process

## 2. Safety

- Do not change the temperature, set at 90 °C
- Use is made of a key-lock to prevent unauthorized program entry
- Do not adjust the vacuum gauge set-points
- Pressure in the chamber should never reach atmospheric during the NH<sub>3</sub> filling step # 16. The door provides a vacuum seal only. If chamber reaches atmospheric pressure, NH<sub>3</sub> will flow freely into the area.

# University of Minnesota Nano Fabrication Center

## Standard Operating Procedure

**Any smell of ammonia would signify a leak. In such an event, immediately hit RESET, then dial the thumb wheel switch to two (2), and press the START button. This activates the pump down cycle shown in section d. Evacuate area.**

### 3. Restrictions/requirements

- Must be a qualified user on the YES 310 image reversal system
- Avoid placing any objects on top of the oven

### 4. Required facilities

- Low pressure nitrogen gas for purging
- High pressure nitrogen or air (70 – 80 psig) to operate the nupro valves
- Electrical power
- Vacuum pump
- Anhydrous ammonia at 10 – 15 psig
- Connection of pump exhaust to scrubbed house exhaust

### 5. Definitions

- Temperature controller set-point : 90 C
- Pressure controller set-point #1: 500 torr
- Pressure controller set-point #2: 10 torr
- Atmospheric pressure = 760 torr
- Lark Sequencer: a sequential process controller which functions as a programmable counter, timer, or fully interactive process controller. The sequencer's LCD display on the front of the unit provides the constant display of status information regarding the mode and the controller's current active sequence. It also shows the current step, including function and data information, and the state of all outputs.

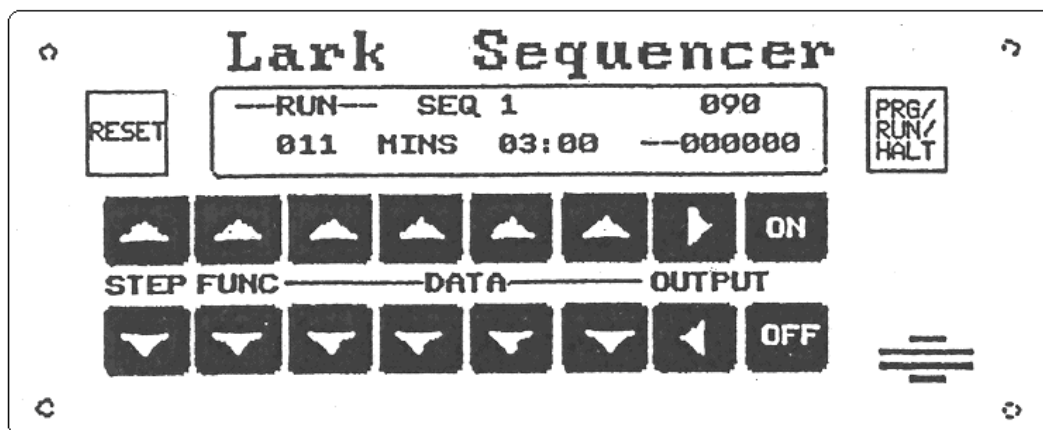

Figure 2: The Lark Sequencer screen

# University of Minnesota Nano Fabrication Center

## Standard Operating Procedure

### 6. Setup

Verify that the Lark sequencer shows the proper sequence number (**SEQ #**) as outlined below. Verify that the temperature is 90 °C. Incomplete or unstable image reversal is possible when inappropriate temperatures are used.

### 7. Operating instructions

#### a. Vent the YES310 oven

1. Press the **RESET** button. This will ensure that you do not restart a program that was halted.
2. Confirm that **SEQ # 2** is on the top line of the display. If it is different, use the **STEP UP/DOWN** arrow keys to make changes.
3. Dial the thumb wheel switch to **ONE (1)**.
4. Press the **START** button.

**Table 1: Vent program**

Step	Func/data	Output	Comments
055	MIN 2:00	3	2 minutes of vacuum
056	MIN 5:00	2	5.00 minutes of low pressure N <sub>2</sub>

5. The program will open the vacuum valve for 2 minutes, to pump out any fumes that may have been left in the chamber.
6. The next step will vent the chamber with low pressure nitrogen for five (5) minutes.
7. During this step, unlatch the door handle. The door opens when the pressure reaches atmospheric pressure (760 torr on the pressure gauge). You do not have to wait for the expiry of the 5 minute duration. Press **RESET** when the door opens and load your substrate.
8. Note: If you do not press **RESET**, the program will still go into **RESET** mode after the timed duration of nitrogen backfill expires.

#### b. Place Substrates in the Oven

There is glassware available for 100mm wafer size which is kept inside the oven. Use suitable grip for the glassware right out of the oven as it will be hot. For other size or shape substrates, lay your substrates flat on the glassware, or flat on the **top shelf**. Always use the **top shelf** to obtain uniform substrate coverage. Close the door, making sure that the latch is securely in place.

# University of Minnesota Nano Fabrication Center

## Standard Operating Procedure

### c. Image Reversal Process

1. Make sure tool is in **RESET** mode
2. Use **STEP UP/DOWN** arrow keys to move to **SEQ #2** if a different sequence shows on the screen.
3. Dial the thumb wheel switch to Zero (**0**).
4. Press **START** button.

# University of Minnesota Nano Fabrication Center

## Standard Operating Procedure

**Table 2: General Description of the YES Image Reversal Process**

<b>Stage 1</b>	<b>Dehydration and purging oxygen from the chamber</b>	
	Function	Time
1	Bake at atmosphere	10 minutes
2	Vacuum (10 Torr)	1:00 min
3	Nitrogen (600 Torr)	~ 2 min 10 sec
4	Vacuum (10 Torr)	1:00 min
5	Nitrogen (600 Torr)	~ 2 min 10 sec
6	Vacuum (10 Torr)	1:00 min
7	Nitrogen (600 Torr)	~ 2 min 10 sec
<b>Stage 2</b>	<b>Ammonia exposure</b>	
8	Vacuum (10 Torr)	32 sec
9	NH3 fill (~ 600 Torr)	~ 8:00 minutes
10	Ammonia bake	45:00 minutes
<b>Stage 3</b>	<b>Purging Ammonia gas exhaust</b>	
11	Vacuum	1:00 min
12	Nitrogen	~ 2 min 10 sec
13	Vacuum	1:00 min
14	Nitrogen	~ 2 min 10 sec
15	Vacuum	1:00 min
16	Nitrogen	~ 2 min 10 sec
17	Vacuum	1:00 min
18	Nitrogen	~ 2 min 10 sec
19	Vacuum	1:00 min
20	Nitrogen	~ 2 min 10 sec
21	Vacuum	1:00 min
<b>Stage 4</b>	<b>Return to atmosphere (Backfill)</b>	
22	Nitrogen	2:00 min
	Total cycle time	~ 90:00 min

5. There is an initial 10 minute bake period at atmosphere.
6. The tool will then start the process by pumping down. Wait and observe the pressure drop to 100 torr during the vacuum step, and rise to 600 torr in the N<sub>2</sub> backfill step, to ensure that the process begins normally.
7. Note the run time for your process and be sure to be at the tool when the process finishes. The tool may abort several minutes into the run if there is a problem.

# University of Minnesota Nano Fabrication Center

## Standard Operating Procedure

**\*NOTE\***: If a cycle is interrupted by a *poor vacuum or no N<sub>2</sub> signal*, the program will automatically jump to an **ABORT** cycle. The **ABORT** light flashes and the sonalert will sound. The **STEP** number displayed will indicate the cause of the **ABORT**:

1. If the displayed **STEP** number is 035 or 036, you have encountered vacuum problems. The vacuum set-point has not been achieved.
2. If the displayed **STEP** number is 040 or 041, you have encountered N<sub>2</sub> backfill problems. Backfill duration needs adjustment on the program.
3. If the displayed **STEP** number is between 045 & 052, you have encountered ammonia problems. Ammonia pressure set-point not achieved. Allow the system to backfill completely with N<sub>2</sub> until the vacuum gauge indicates the system is at atmospheric pressure before pressing the **RESET** button. This will take approximately 2½ minutes.

8. The next 6 functions (vacuum, nitrogen, vacuum...) remove oxygen and humidity from the chamber. The purge cycle creates an inert environment for ammonia to enter. The removal of humidity avoids the build-up of ammonium hydroxide in the system and on the wafers. A vacuum step precedes the introduction of ammonia.
9. When ammonia is introduced the chamber pressure steadily rises from about 100 torr to 600 torr in approximately 8 minutes. At the upper pressure, the microprocessor closes the Nupro valve, to prevent the chamber door from being opened during the process, releasing ammonia into the area.

If during the ammonia backfill, the set-point is not reached within the programmed time, the run will abort and an alarm will sound. The displayed **STEP** number will be a number between 045 & 052 depending on when you make the observation. The program will then proceed to expunge the NH<sub>3</sub> through 4 cycles of pump down and N<sub>2</sub> purge. Allow these cycles to proceed before pressing **RESET** on the last N<sub>2</sub> purge step.

10. After the ammonia backfills successfully, the wafers/substrates are baked in it for 45 minutes. During this time, both the nitrogen, ammonia and vacuum valves are closed and pressure remains constant.

**At this point, the chamber is filled with ammonia, and it is also under a slight vacuum. Though unlikely, any smell of ammonia would indicate a leak. In such an event, immediately hit RESET, and then dial the thumb wheel switch to two (2), and press the START button. This activates the pump down cycle shown in section d. Evacuate area.**

11. Another cycle of pump-down and vent (vacuum, nitrogen, vacuum...), safely remove the ammonia fumes from the chamber without reaching atmospheric pressure. The final function returns the system to atmospheric pressure making it possible to open the door and remove the wafers.

# University of Minnesota Nano Fabrication Center

## Standard Operating Procedure

- When the process is done, the amber **COMPLETE** light will flash and an alarm will sound. These will both turn off by themselves after 5 minutes or you can press the **RESET** button. The Lark sequencer will display STEP number **29** during the five minutes at the end of the process when the program runs normally.

**\*NOTE\***: Even though the oven is purged after a process and there are no chemical fumes, the *oven surfaces will evolve a small amount of ammonia*. For this reason, please keep your face away from the door when opening the oven.

### d. Pump down YES-310 after a run

- Confirm that **SEQ # 2** is on the top line of the display. If it is different, use the **STEP UP/DOWN** arrow keys to make changes.
- Dial the thumb wheel switch to two (**2**).
- Press the **START** button or the **PGR/RUN/HALT** button.

**Table 3: Pump-down after use program**

Step	Func/data	Output	Comments
058	MIN 2:00	3	2 minutes of vacuum
059	MIN 2:00	2	2 minutes of low pressure N <sub>2</sub> to ~ 600 torr

- The program will open the vacuum valve for 2 minutes, to pump down to approximately 1 torr.
- The next step will vent the chamber with low pressure nitrogen for two minutes and raise the pressure to about 600 torr. The system can be left in this position.

# University of Minnesota Nano Fabrication Center

## Standard Operating Procedure

### Appendix 1: Image Reversal Process Program – Seq. # 2

Step	Func/Data	Output	Comments
001	IF A > 055		If 1,3,5,7,9 are dialed on the Thumbwheel, go to step 055
002	IF C > 058		If 2,3,6,7 are dialed on the Thumbwheel, go to step 058
003	MINS 10:00		10 minute bake
004	LOOPC = 0003		Load 3 into Loop memory
005	MINS 01:00	3	1:00 min of vacuum to 100 torr (adjust time as needed)
006	IF B > 035		ABORT, vacuum problem. Go to step 035
007	LOOPC = 240		Load 240 into Loop memory
008	SECS 01:00	2	Nitrogen backfill to set-point 1 (600 torr)
009	IF B > 012	2	Check set-point 1
010	LOOPJ > 008	2	Subtract 1 from number in Loop memory
011	GO TO > 040		Set-point 1 not obtained. ABORT to step 040
012	LOOPJ > 012		Clear Loop memory
013	LOOPJ > 005		Subtract 1 from number in Loop memory. Go to 005.
014	MINS 00:32	3	32 sec of vacuum to 100 torr (adjust time as needed)
015	IF B > 035		ABORT, vacuum problem, go to step 035
016	LOOPC = 720		Load 720 in Loop memory
017	SECS 01:00	4	1 second of ammonia backfill to 600 torr
018	IF B > 021	4	Check set-point 1
019	LOOPJ > 017	4	Subtract 1 from number in Loop memory, go to 017.
020	GO TO > 045		ABORT, ammonia problem. Go to step 045
021	MINS 45:00		45 minutes of ammonia image neutralization
022	LOOPC = 0004		Load 4 into Loop memory
023	MINS 01:30	3	1½ minute vacuum to 100 torr
024	SECS 01:00	2	Nitrogen backfill to set-point 1 (600 torr)
025	IF B > 027	2	Check set-point 1
026	GO TO > 024	2	Go to step 024
027	LOOPJ > 023		Subtract 1 from number in Loop memory
028	MINS 02:00	2	Nitrogen backfill to atmosphere
029	MINS 5:00	1,5	5 minutes complete
030	SECS 01:00	1	1 second complete light
031	GO TO > 000		Not used
032	GO TO > 000		Not used
033	GO TO > 000		Not used
034	GO TO > 000		Not used
035	SECS 00:50	1,2,5	Abort from step 006 or 015. Vacuum problem
036	SECS 00:50	1,2,5	Continuous nitrogen with ABORT light and Sonalert
037	GO TO > 035	2,5	Sonalert every ½ second
038	GO TO > 000		Not used
039	GO TO > 000		Not used
040	SECS 00:50	1,2,5	ABORT from step 011. Nitrogen backfill problem
041	SECS 00:50	1,2,5	Continuous nitrogen with ABORT light and Sonalert
042	GO TO > 040	2,5	Sonalert every ½ second
043	GO TO > 000		Not used

# University of Minnesota Nano Fabrication Center

## Standard Operating Procedure

Step	Func/Data	Output	Comments
044	GO TO > 000		Not used
045	LOOPC = 0004		ABORT from step 020. Ammonia backfill problem. Load 4 into Loop memory
046	MINS 01:30	3	1:30 minutes of vacuum
047	SECS 01:00	2	Nitrogen backfill to set-point 1 (600 torr)
048	IF B > 050	2	Check set-point 1
049	GO TO > 047	2	Go to step 047
050	LOOPJ > 046		Subtract 1 from number in Loop memory
051	SECS 00: 50	1,2,5	Continuous nitrogen with ABORT light and Sonalert
052	SECS 00:50	2,5	Continuous nitrogen with and Sonalert
053	GO TO > 051	2,5	Continuous nitrogen with and Sonalert
054	GO TO > 000		Not used
055	MINS 02:00	3	2 minute vacuum to approx. 1 torr
056	MINS 05:00	2	Nitrogen backfill
057	GO TO > 000		Not used
058	MIN 2:00	3	2 minutes of vacuum
059	MIN 2:00	2	2 minutes of low pressure N2
060	GO TO > 000		RESET